

# FRIALEN® - Obejmy do nawiercania DAA (KIT) nawiercanie pod ciśnieniem, pakowane łącznie z mufą MB lub mufą redukcyjną MR **PE 100 SDR 11**

Maksymalne dopuszczalne ciśnienie robocze 16 bar (woda) / 10 bar (gaz)

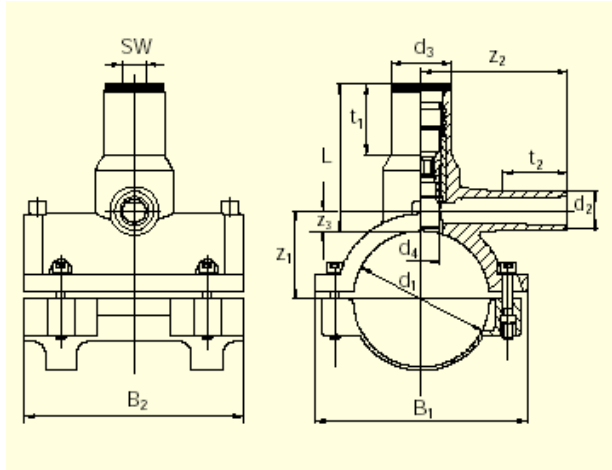

d <sub>1</sub>	d <sub>2</sub>	Nr katal.	Status magaz.	VE	PE	d <sub>3</sub>	L	z <sub>1</sub>	z <sub>2</sub>	z <sub>3</sub>	t <sub>1</sub>	t <sub>2</sub>	B <sub>1</sub>	B <sub>2</sub>	SW	d <sub>4</sub>	Masa kg/szt.
63	32	T-615 649	1	16	288	40	100	47	88	15,5	45	44	98	105	17	21	0,527
75 <sup>1</sup>	32 <sup>2</sup>	T-615 651	1	12	216	40	100	52,5	88	15	45	44	112	105	17	21	0,728
90 <sup>1</sup>	20 <sup>2</sup>	T-615 653	2	12	96	50	116	63,5	100	18,5	59	44	155	150	19	30	1,166
90 <sup>1</sup>	25 <sup>2</sup>	T-615 654	2	12	96	50	116	63,5	105	18,5	59	47	155	120	19	30	1,171
90 <sup>1</sup>	32	T-615 655	1	12	96	50	116	63,5	140	18,5	59	85	155	120	19	30	1,184
90 <sup>1</sup>	40 <sup>2</sup>	T-615 656	1	12	96	50	116	63,5	120	18,5	59	57	155	150	19	30	1,304
110 <sup>1</sup>	20 <sup>2</sup>	T-615 659	2	16	128	50	116	73,5	105	18,5	59	44	175	120	19	30	1,145
110 <sup>1</sup>	25 <sup>2</sup>	T-615 660	2	16	128	50	116	73,5	110	18,5	59	47	175	120	19	30	1,150
110 <sup>1</sup>	32	T-615 661	1	16	128	50	116	73,5	130	18,5	59	85	175	120	19	30	1,163
110 <sup>1</sup>	40 <sup>2</sup>	T-615 662	1	16	128	50	116	73,5	115	18,5	59	57	175	120	19	30	1,285
110 <sup>1</sup>	50 <sup>2</sup>	T-615 663	1	16	128	50	116	73,5	165	18,5	59	105	175	120	19	30	1,294
125	20 <sup>2</sup>	T-615 665	2	10	80	50	116	81	110	18,5	59	44	190	125	19	30	1,516
125	25 <sup>2</sup>	T-615 666	2	10	80	50	116	81	115	18,5	59	47	190	125	19	30	1,521
125	32	T-615 667	1	10	80	50	116	81	145	18,5	59	85	190	125	19	30	1,534
125	40 <sup>2</sup>	T-615 668	1	10	80	50	116	81	132	18,5	59	57	190	125	19	30	1,657
160	20 <sup>2</sup>	T-615 672	2	6	48	50	162	109	100	29	59	47	225	195	19	30	1,936
160	25 <sup>2</sup>	T-615 673	2	6	48	50	162	112	105	32	59	50	225	195	19	30	1,941
160	32	T-615 674	1	6	48	50	162	114	130	34	59	85	225	195	19	30	1,954
160	40 <sup>2</sup>	T-615 675	1	6	48	50	162	111	115	31	59	60	225	195	19	30	2,081

Obejmy DAA (KIT) FRIALEN® można zgrzewać z rurami typoszeregu SDR 17.6 do 11

<sup>1</sup> można zgrzewać z rurami do SDR 7.4

<sup>2</sup> z redukcjami d32/20, d32/25, d40/32 lub d50/40