

**FRIALEN®-Repair Saddle****Top-Loading VSC-TL****PE 100 SDR 11**

Maximum working pressure 16 bar (Water) / 10 bar (Gas)

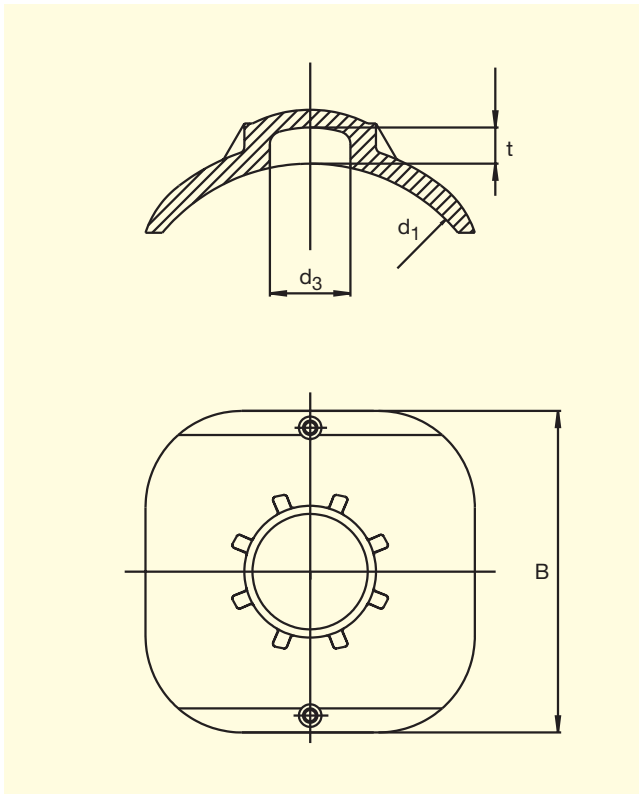

d <sub>1</sub>	d <sub>3</sub>	Order Ref.	Stock-status	VE	PE	t	B	Weight kg/each
250-500	50	T-615 397	1	10	180	20	200	0.600

FRIALEN®-Safety Fittings can be fused to pipes of SDR stages 11 to 17.6  
 DVGW-Registration No.: DV-8611AU2250

Please turn over for important information regarding application of the  
**FRIALEN®-Repair Saddle VSC-TL**

# **FRIALEN<sup>®</sup>-Repair Saddle**

## **Top-Loading VSC-TL**

### **PE 100 SDR 11**

Maximum working pressure 16 bar (Water) / 10 bar (Gas)

#### **Areas of Application**

The FRIALEN<sup>®</sup>-Repair Saddle Top-Loading VSC-TL is used for the repair of minor pipe damages **with and without** discharge of media.

#### **Assembly Instructions**

The saddle is suitable for all pipe diameters in the given range. It is clamped onto the pipe by means of the FRIATOP clamping unit (see product range "Technical Equipment"). Please read the "Assembly and Operating Instructions for FRIATOP Clamping Unit (Top-Loading)".

The fusion of the HD-PE distribution pipes with the FRIALEN<sup>®</sup>-Repair Saddle takes place by FRIALEN<sup>®</sup>-fusing – leakproof and longitudinally strong.

In order to avoid discharge of media, the leak has to be sealed with a separate plug ( $\leq d_3$ ).

The pipe and the saddle have to be prepared according to the general installation instructions (see "Assembly Instructions" for "FRIALEN<sup>®</sup>-Special Technology for laying large bore pipes and relining pipe networks  $\geq d 250$ "). This involves removing the oxide layer and cleaning the pipe covered by the saddle.

#### **Six good reasons for using the FRIALEN<sup>®</sup>-VSC-TL**

- **Compact construction**
- **HD-PE saddle with exposed heating element for optimal heat transfer**
- **Sealing area free of heating wires**
- **Extra wide fusion zone**
- **The VSC-TL can be applied universally to large HD-PE pipe diameters d 250-560. This means additional economy since less material is needed and less stock at both suppliers and trade is necessary.**
- **Additional barcode for tracing back the fitting (Traceability-Coding).**

Please find our datasheets for downloading on the internet at [www.friatec.de](http://www.friatec.de)

**For further information, please call our FRIALEN<sup>®</sup>-customer service and specialist advisers.**