

Index to ABS Metric Fittings

Note: Two-dimensional Auto-CAD drawings are available on www.durapipe.co.uk



Pipe (plain)
page 54



Sockets (plain)
page 54



Reducing bushes
(plain)
page 55



Reducing sockets
(plain)
page 55



Elbows 45°
(plain)
page 55



Elbows 90°
(plain)
page 56



Tees 45° (plain)
page 56



Tees 90° (equal)
page 56



Tees 90° (swept plain)
page 57



Tees 90° (reducing plain)
page 57



Bends 90°
(short radius)
page 57



Bends 90°
(long radius)
page 58



End caps (plain)
page 58



Socket unions (plain)
page 58



Imperial/metric socket
adaptors (plain)
page 58



Male threaded adaptors
(BSP taper male thread)
page 59



Female threaded adaptors
(plain spigot/plain
socket/female BSP thread)
page 59



Male threaded fittings
(plain/brass male thread)
page 59



Female threaded fittings
(plain/brass female thread)
page 60



Half faced unions
page 60



Hose adaptors
(spigot end/hose tail)
page 60



Female composite unions
(plain/brass, female BSP
parallel thread) page 60



Male composite unions
(plain/brass, male BSP
parallel thread)
page 61



Flexible hoses
(plain spigot/BSP thread)
page 61



Wall brackets
(ABS/brass body)
page 61



Flanges stub
(plain serrated)
page 62



Flanges blanking
page 62



Backing rings
(galvanised mild steel)
page 63

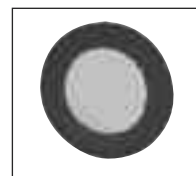

Flat gaskets for use with
stub flanges
page 64



Valve support plates
(galvanised mild steel)
page 64



O-Ring sockets
(galvanised mild steel)
page 64

Valves



VKD Double union ball valves (manual – EPDM seals) page 65



TKD 3-way ball valves (manual – EPDM seals) page 65



EV Double union ball valves (manual – EPDM seals) page 66



UC Ball check valves (EPDM seals) page 66



UA Air release valves (EPDM seals) page 66



RV Y-Type strainers (plain ends – EPDM seals) page 67



VM Diaphragm valves (manual – plain union ends – EPDM seals) page 67



PR Pressure relief valves (EPDM seals) page 67



FK Butterfly valves (glass reinforced polypropylene with ABS disc) page 68

Accessories



Cobra pipe clips page 68

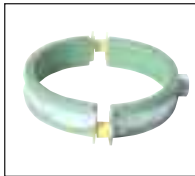

Rubber lined pipe clips page 69



One-step solvent cement page 69



Eco-cleaner page 69

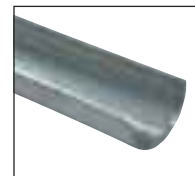

Pipe trays page 70



Chamfering and de-burring tools page 70



Pipe cutters page 69

ABS Pipe metric system Plain PN10

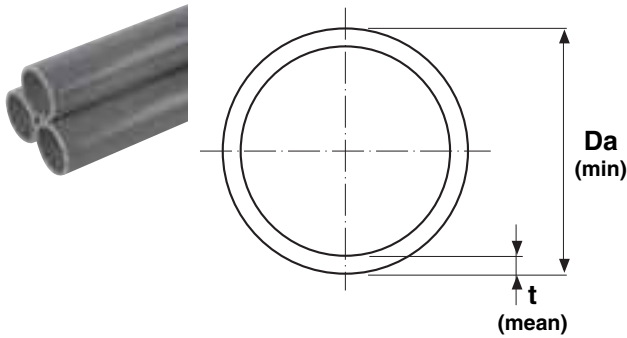

Size	Thickness t mm	Weight kg/m	Length m	Code
16	1.5	0.07	3	11 565 305
20	1.6	0.10	3	11 565 306
25	1.9	0.14	3	11 565 307
35	2.1	0.21	3	11 565 308
16	1.5	0.07	5	11 555 305
20	1.6	0.10	5	11 555 306
25	1.9	0.14	5	11 555 307
32	2.1	0.21	5	11 555 308
40	2.7	0.33	5	11 555 309
50	3.4	0.52	5	11 555 310
63	4.2	0.81	5	11 555 311
75	5.0	1.14	5	11 555 312
90	6.0	1.65	5	11 555 313
110	7.3	2.45	5	11 555 314
125	8.2	3.13	5	11 555 315
140	9.3	3.97	5	11 555 316
160	10.5	5.13	5	11 555 317
200	13.2	8.06	5	11 555 318
225	14.8	10.17	5	11 555 319
250	16.1	12.31	5	11 555 320
*315	20.8	20.00	5	11 555 323
16	1.5	0.07	6	11 551 305
20	1.6	0.10	6	11 551 306
25	1.9	0.14	6	11 551 307
32	2.1	0.21	6	11 551 308
40	2.7	0.33	6	11 551 309
50	3.4	0.52	6	11 551 310
63	4.2	0.81	6	11 551 311
75	5.0	1.14	6	11 551 312
90	6.0	1.65	6	11 551 313
110	7.3	2.45	6	11 551 314
125	8.2	3.13	6	11 551 315
140	9.3	3.97	6	11 551 316
160	10.5	5.13	6	11 551 317
200	13.2	8.06	6	11 551 318
225	14.8	10.17	6	11 551 319
250	16.1	12.31	6	11 551 320
*315	20.8	20.00	6	11 551 323

*315 is PN8 rated.

Sockets Plain

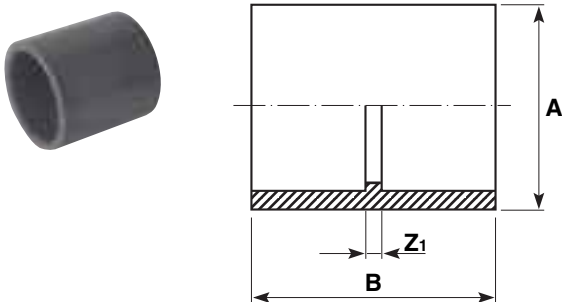

Size	PN	A	B	Z ₁	gms	Code
16	10	21	31	3	5	11 100 305
20	10	25	37	3	7	11 100 306
25	10	31	42	2	12	11 100 307
32	10	41	49	3	25	11 100 308
40	10	50	58	4	45	11 100 309
50	10	62	68	4	77	11 100 310
63	10	78	81	4	154	11 100 311
75	10	88	93	3	230	11 100 312
90	10	107	108	4	380	11 100 313
110	10	126	131	7	690	11 100 314
125	10	146	149	7	1040	11 100 315
140	10	171	163	7	1390	11 100 316
160	10	182	184	8	1660	11 100 317
200	10	223	220	8	2390	11 100 318
225	10	260	250	11	3470	11 100 319
250	10	286	272	10	5760	11 100 320
315	8	355	339	11	9780	11 100 323

Reducing bushes Plain

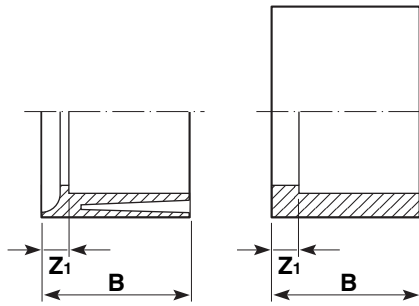
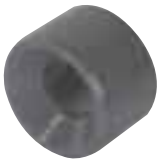

Size	PN	B	Z ₁	gms	Code
20 x 16	10	17	3	2	11 109 412
25 x 20	10	19	3	4	11 109 415
32 x 16	10	23	9	5	11 109 417
32 x 25	10	23	8	6	11 109 419
40 x 32	10	28	6	13	11 109 423
50 x 20*	10	33	17	32	11 109 424
50 x 25*	10	33	13	29	11 109 425
50 x 32*	10	32	11	19	11 109 426
50 x 40	10	32	5	25	11 109 427
63 x 25*	10	39	20	60	11 109 429
63 x 32*	10	39	16	36	11 109 430
63 x 50	10	39	7	47	11 109 432
75 x 63	10	46	7	65	11 109 438
90 x 50*	10	54	23	200	11 109 442
90 x 63*	10	54	15	224	11 109 443
90 x 75	10	55	9	110	11 109 444
110 x 63*	10	64	25	252	11 109 449
110 x 90	10	64	10	200	11 109 451
125 x 110	10	72	9	220	11 109 459
140 x 125	10	79	8	260	11 109 467
160 x 90	10	89	35	320	11 109 473
160 x 110*	10	89	27	405	11 109 474
160 x 140	10	89	10	460	11 109 476
200 x 160	10	110	21	109	11 109 487
225 x 160*	10	122	33	1600	11 109 495
225 x 200*	10	122	13	1250	11 109 496
250 x 225*	10	132	12	2230	11 109 499
315 x 250*	8	165	33	5080	11 109 503

*Configuration shown in inset.

Reducing sockets Plain

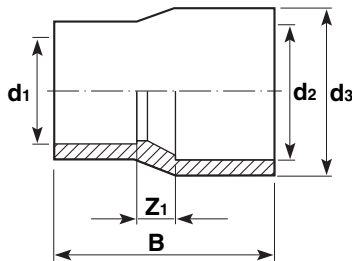

PN	d ₃	d ₂	d ₁	B	Z ₁	gms	Code
10	25	20	16	37	6	6	11 114 412
10	32	25	20	42	6	12	11 114 415
10	40	32	25	50	8	22	11 114 419
10	50	40	32	60	11	39	11 114 423
10	63	50	40	71	11	80	11 114 427
10	75	63	50	85	14	108	11 114 432
10	90	75	63	98	13	190	11 114 438
10	110	90	75	115	16	350	11 114 444
10	125	110	90	140	21	480	11 114 451
10	140	125	110	156	20	690	11 114 459
10	160	140	125	170	20	1000	11 114 467
10	200	160	140	193	23	2180	11 114 476
10	225	200	160	237	41	2530	11 114 487

Elbows 45° Plain

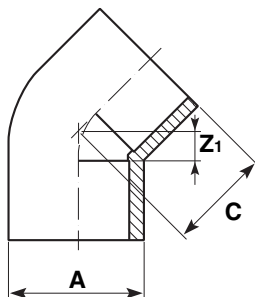

Size	PN	A	C	Z ₁	gms	Code
16	10	21	20	5	5	11 119 305
20	10	25	22	5	7	11 119 306
25	10	31	26	7	14	11 119 307
32	10	40	31	8	27	11 119 308
40	10	50	37	10	54	11 119 309
50	10	62	45	13	100	11 119 310
63	10	82	54	16	180	11 119 311
75	10	90	63	17	300	11 119 312
90	10	112	70	18	550	11 119 313
110	10	137	90	27	950	11 119 314
125	10	155	103	31	1350	11 119 315
140	10	173	115	37	1980	11 119 316
160	10	190	125	35	2920	11 119 317
200	10	230	152	44	3460	11 119 318
225	10	260	174	51	4920	11 119 319
250	10	286	189	58	5900	11 119 320
315	8	359	230	66	11880	11 119 323

Elbows 90° Plain

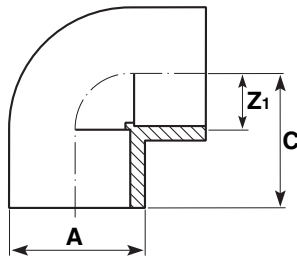

Size	PN	A	C	Z ₁	gms	Code
16	10	20	24	10	6	11 115 305
20	10	25	28	11	10	11 115 306
25	10	31	34	15	17	11 115 307
32	10	40	41	18	35	11 115 308
40	10	50	47	20	68	11 115 309
50	10	62	59	26	129	11 115 310
63	10	78	71	31	230	11 115 311
75	10	90	83	38	385	11 115 312
90	10	112	100	49	690	11 115 313
110	10	136	125	63	1220	11 115 314
125	10	155	140	63	1720	11 115 315
140	10	173	153	76	2390	11 115 316
160	10	190	172	79	3600	11 115 317
200	10	235	207	110	4300	11 115 318
225	10	261	240	119	6550	11 115 319
250	10	286	319	188	9560	11 115 320
315	8	359	400	236	17910	11 115 323

Tees 45° Plain

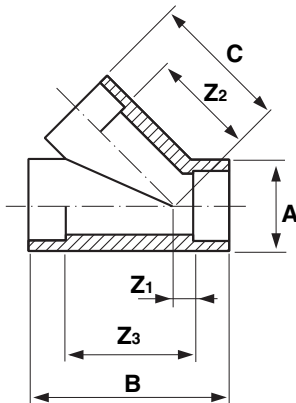

Size	PN	A	B	C	Z ₁	Z ₂	Z ₃	gms	Code
20	10	28	68	43	6	26	34	30	11 418 306
25	10	33	81	52	7	29	55	45	11 418 307
32	10	41	98	65	9	42	52	80	11 418 308
40	10	50	117	77	11	51	65	135	11 418 309
50	10	60	140	95	12	63	78	195	11 418 310
63	10	74	169	114	13	76	93	410	11 418 311

Tees 90° Equal

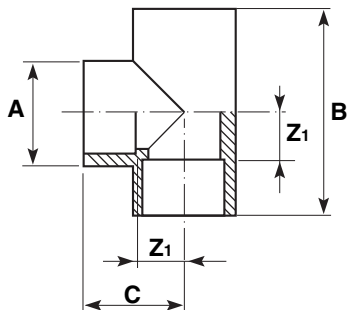

Size	PN	A	B	C	Z ₁	gms	Code
16	10	21	47	25	10	7	11 122 305
20	10	25	57	30	12	12	11 122 306
25	10	31	67	34	15	24	11 122 307
32	10	40	81	43	18	48	11 122 308
40	10	50	99	50	23	87	11 122 309
50	10	62	119	62	28	160	11 122 310
63	10	78	146	70	34	300	11 122 311
75	10	90	172	87	36	510	11 122 312
90	10	112	205	104	46	900	11 122 313
110	10	132	248	128	60	1650	11 122 314
125	10	154	276	143	67	2300	11 122 315
140	10	172	307	153	72	3200	11 122 316
160	10	191	343	172	86	4800	11 122 317
200	10	237	413	206	101	5800	11 122 318
225	10	262	482	240	120	7700	11 122 319
250	10	286	518	259	128	10160	11 122 320
315	8	360	652	326	162	19390	11 122 323

Tees 90° Swept plain

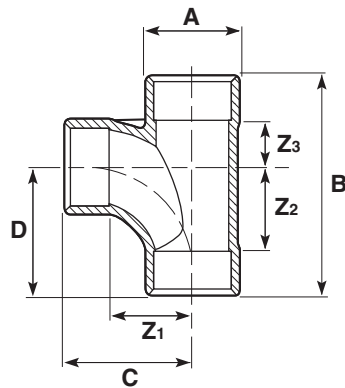

Size	PN	A	B	C	D	Z ₁	Z ₂	Z ₃	gms	Code
32	10	41	115	79	79	57	57	14	90	11 148 308
50	10	62	160	105	105	74	74	24	259	11 148 310
63	10	78	195	125	125	87	87	32	480	11 148 311
75	10	92	210	125	125	81	81	41	601	11 148 312
110	10	139	315	190	190	127	127	62	2235	11 148 314

Tees 90° Reducing plain

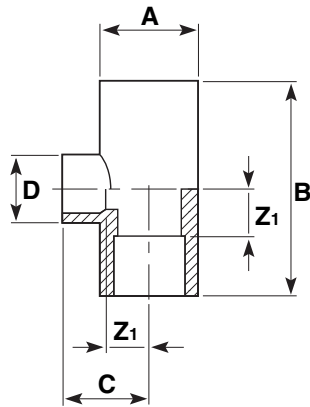

Size	PN	A	B	C	D	Z ₁	gms	Code
25 x 20	10	31	67	31	25	14	22	11 124 415
32 x 20	10	40	81	35	25	18	40	11 124 418
32 x 25	10	40	81	37	31	18	41	11 124 419
40 x 20	10	50	98	39	25	22	72	11 124 421
40 x 25	10	50	98	41	31	22	72	11 124 422
50 x 20	10	62	119	44	29	27	104	11 124 424
50 x 25	10	62	119	46	31	27	140	11 124 425
50 x 32	10	62	119	50	40	27	140	11 124 426
63 x 25	10	78	146	53	31	34	250	11 124 429
63 x 32	10	78	146	57	40	34	250	11 124 430
75 x 32	10	91	168	62	41	40	391	11 124 435
75 x 40	10	91	168	66	50	40	398	11 124 436
75 x 50	10	91	168	71	61	40	406	11 124 437
75 x 63	10	91	168	78	76	40	428	11 124 438
90 x 40	10	109	198	74	50	48	642	11 124 441
90 x 50	10	109	198	79	61	48	649	11 124 442
90 x 63	10	109	198	86	76	48	664	11 124 443
90 x 75	10	109	198	92	91	48	693	11 124 444
110 x 50	10	133	244	92	61	61	1165	11 124 448
110 x 63	10	133	244	99	76	61	1173	11 124 449
110 x 75	10	133	244	105	91	61	1188	11 124 450
110 x 90	10	133	244	112	109	61	1210	11 124 451

Bends 90° Short radius

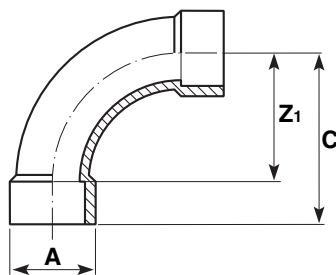

Size	PN	A	C	Z ₁	gms	Code
20	10	26	57	40	18	11 118 306
25	10	33	69	50	38	11 118 307
32	10	41	87	64	75	11 118 308
40	10	51	107	80	135	11 118 309
50	10	62	132	100	245	11 118 310
63	10	78	165	126	470	11 118 311
75	10	93	195	150	810	11 118 312
90	10	111	234	180	1350	11 118 313
110	10	140	284	220	2570	11 118 314

Bends 90° Long radius

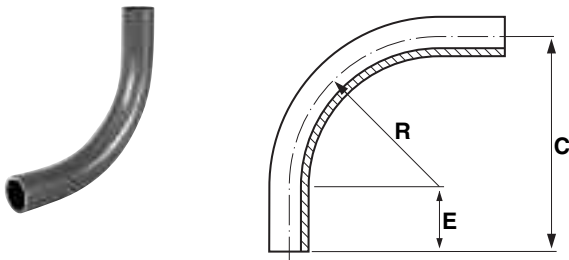

Size	C	E	R	gms	Code
125	750	250	500	4790	11 309 315
140	840	280	560	6700	11 309 316
160	960	320	640	10040	11 309 317
200	1200	400	800	19480	11 309 318
225	1350	450	900	27850	11 309 319

End caps Plain

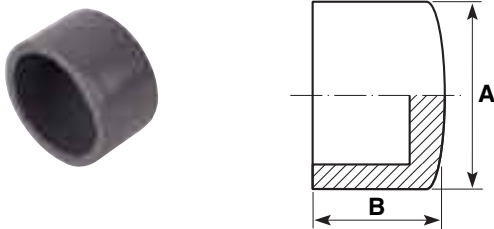

Size	PN	A	B	Weight gms	Code
16	10	21	16	3	11 149 305
20	10	25	21	5	11 149 306
25	10	31	24	8	11 149 307
32	10	41	30	19	11 149 308
40	10	50	35	30	11 149 309
50	10	62	41	53	11 149 310
63	10	78	50	106	11 149 311
75	10	94	59	180	11 149 312
90	10	112	70	300	11 149 313
110	10	136	84	570	11 149 314

Socket unions Plain

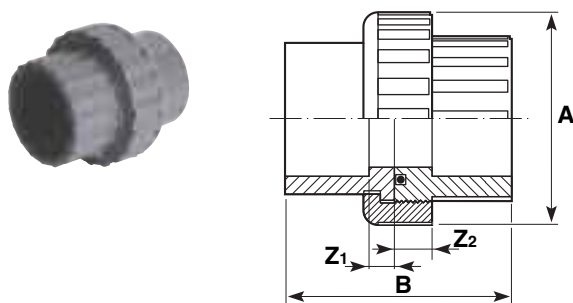

Size	PN	A	B	Z ₁	Z ₂	Weight gms	Code
16	10	34	42	3	10	19	11 205 305
20	10	40	47	3	10	29	11 205 306
25	10	50	53	3	10	46	11 205 307
32	10	57	64	8	11	70	11 205 308
40	10	73	78	10	13	140	11 205 309
50	10	80	92	13	15	154	11 205 310
63	10	102	111	14	20	270	11 205 311
75	10	135	107	8	13	720	11 205 312
90	10	157	115	7	4	750	11 205 313
110	10	183	138	8	7	1115	11 205 314

EPDM seal as standard.
For FPM seal order by type 204.

Imperial/metric socket adaptors Plain

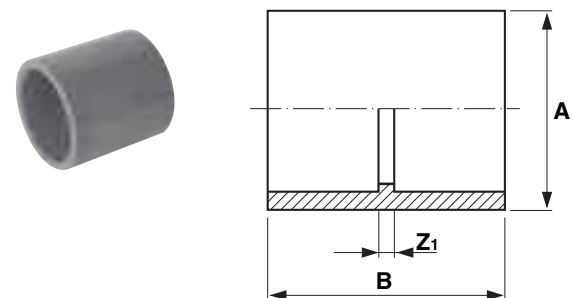

Size	PN	A	B	Z ₁	Weight gms	Code
*1/2 - 20	10	26	37	3	11	11 345 102
*3/4 - 25	10	31	41	3	23	11 345 103
*1 - 32	10	40	49	3	40	11 345 104
*1 1/4 - 40	10	50	58	2	80	11 345 105
*1 1/2 - 50	10	59	67	3	160	11 345 106
*2 - 63	10	74	78	2	230	11 345 107
*3 - 90	10	107	105	3	340	11 345 109
*4 - 110	10	134	130	6	675	11 345 110
*6 - 160	10	195	183	8	1890	11 345 112

*Sizes shown in imperial n.b. designation.

Male threaded adaptors BSP taper male thread

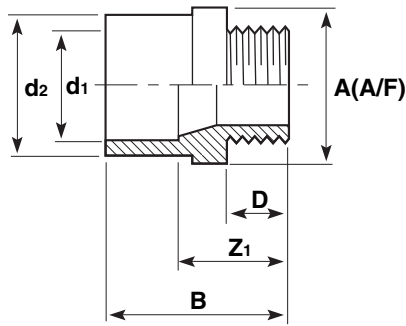

Size		PN	T*	A	B	D	Z ₁	Weight		Code
d ₂	d ₁							gms		
16- 12-	10	10	3/8	19	35	11	22	7		11 151 331
20- 16-	10	10	3/8	24	38	12	24	7		11 151 332
20- 16-	10	10	1/2	24	42	15	28	7		11 151 333
20- 16-	10	10	3/4	30	46	16	28	8		11 151 327
25- 20-	10	10	1/2	30	46	15	28	13		11 151 334
25- 20-	10	10	3/4	30	48	16	31	14		11 151 335
32- 25-	10	10	1/2	36	51	15	32	23		11 151 352
32- 25-	10	10	3/4	36	52	16	33	23		11 151 336
32- 25-	10	10	1	36	55	19	36	23		11 151 337
40- 32-	10	10	1	46	58	20	36	36		11 151 338
40- 32-	10	10	1 1/4	46	60	21	37	38		11 151 339
50- 40-	10	10	1 1/4	55	66	22	39	70		11 151 340
50- 40-	10	10	1 1/2	55	66	21	39	70		11 151 341
63- 50-	10	10	1 1/2	72	73	22	41	115		11 151 342
63- 50-	10	10	2	72	78	26	46	123		11 151 343
75- 63-	10	10	2	80	84	26	46	150		11 151 345

*Thread size designation.

Female threaded adaptors Plain spigot/plain socket/female BSP thread

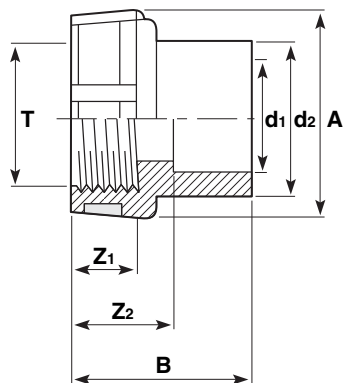

Size		PN	T*	A	B	Z ₁	Z ₂	Weight		Code
d ₂	d ₁							gms		
16- 12-	10	10	3/8	24	28	11	16	7		11 153 331
20- 16-	10	10	1/2	30	35	15	21	14		11 153 333
25- 20-	10	10	3/4	38	39	16	22	21		11 153 335
32- 25-	10	10	1	45	45	18	26	42		11 153 337
40- 32-	10	10	1 1/4	56	54	21	31	69		11 153 339
50- 40-	10	10	1 1/2	64	60	21	33	108		11 153 341
63- 50-	10	10	2	78	72	25	41	169		11 153 343

*Thread size designation.

Male threaded fittings Plain/brass male thread

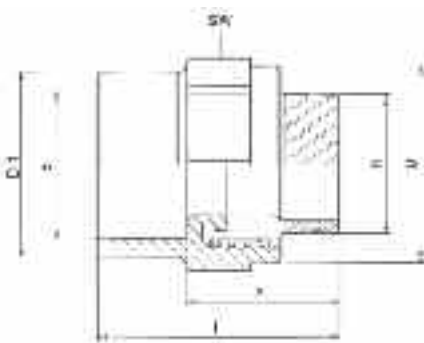

Size	D	D ₁	l	z	SW	Code
20 x 1/2	35	29	55	40	36	11 228 306
25 x 3/4	43	34	58	42	44	11 228 307
32 x 1	50	43	66	48	51	11 228 308
40 x 1 1/4	62	52	74	53	63	11 228 309

ALL Durapipe Brass Components are manufactured using DZR Brass.

Female threaded fittings Plain/brass female thread

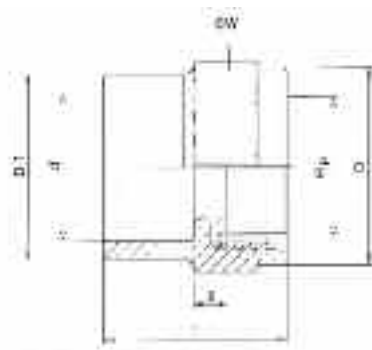

Size	D	D ₁	l	z	SW	Code
20 x 1/2	35	29	40	11	36	11 229 306
25 x 3/4	43	34	42	11	44	11 229 307
32 x 1	50	43	48	12	51	11 229 308
40 x 1 1/4	62	55	54	13	63	11 229 309

ALL Durapipe Brass Components are manufactured using DZR Brass.

Half faced unions

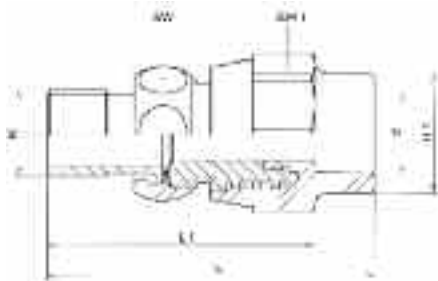

Size	D ₁	L	L ₁	SW	SW ₁	Code
20 x 1/2	29	79	65	36	30	11 230 306
25 x 3/4	34	88	72	44	37	11 230 307
32 x 1	43	98	80	51	46	11 230 308
40 x 1 1/4	52	113	92	63	52	11 230 309

ALL Durapipe Brass Components are manufactured using DZR Brass.

Hose adaptors Spigot end/hose tail

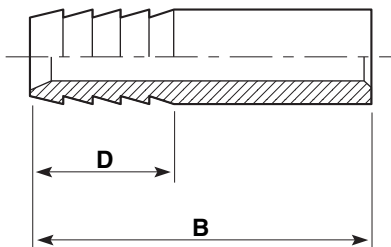

Size	PN	B	D	Weight gms	Code
16	10	60	25	8	11 158 305
20	10	75	30	13	11 158 306
25	10	80	35	20	11 158 307
32	10	90	40	32	11 158 308

Female composite unions Plain/brass, female BSP parallel thread

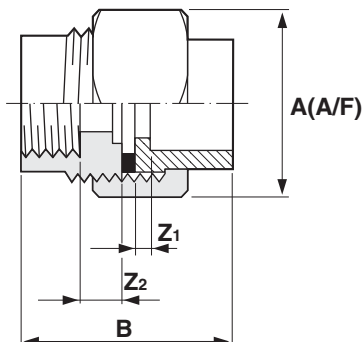

Size	PN	A	B	Z ₁	Z ₂	Weight gms	Code
16 x 3/8*	10	32	37	3	7	105	11 216 305
20 x 1/2*	10	40	43	3	7	175	11 216 306
25 x 3/4*	10	48	47	3	7	320	11 216 307
32 x 1*	10	55	59	8	9	420	11 216 308
40 x 1 1/4*	10	65	68	10	8	620	11 216 309
50 x 1 1/2*	10	78	76	12	9	1000	11 216 310
63 x 2*	10	88	89	12	11	1200	11 216 311

*Thread sizes designation.

Fitted with brass retaining nut and EPDM rubber seal.

Brass material to BS2872, WRAS approved.

ALL Durapipe Brass Components are manufactured using DZR Brass.

Male composite unions Plain/brass, male BSP taper thread

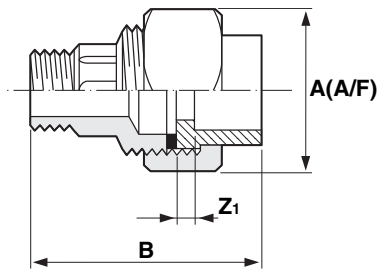

Size	PN	A	B	Z ₁	Z ₂	Weight gms	Code
16 x 3/8*	10	32	48	3	9	100	11 217 305
20 x 1/2*	10	40	54	3	9	165	11 217 306
25 x 3/4*	10	48	74	3	10	250	11 217 307
32 x 1*	10	55	86	8	11	310	11 217 308
40 x 1 1/4*	10	65	94	10	11	450	11 217 309
50 x 1 1/2*	10	78	108	12	12	800	11 217 310
63 x 2*	10	88	126	12	14	950	11 217 311

*Thread sizes designation.

Fitted with brass retaining nut and EPDM rubber seal.

Brass material to BS2872, WRAS approved.

ALL Durapipe Brass Components are manufactured using DZR Brass.

Flexible hoses Plain spigot, BSP thread



Size	Code
20 x 1/2" x 300	11450306
25 x 3/4" x 300	11450307
32 x 1" x 300	11450308
20 x 1/2" x 600	11451306
25 x 3/4" x 600	11451307
32 x 1" x 600	11451308

10 bar working pressure at 20°C.

Other lengths available on request.

ALL Durapipe Brass Components are manufactured using DZR Brass.

Wall brackets ABS/brass body

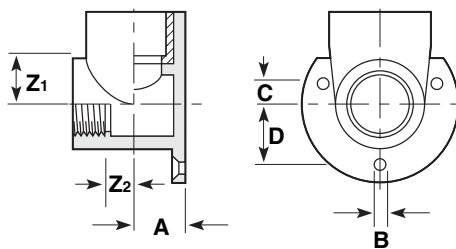

Size	PN	A	B	C	D	Z ₁	Z ₂	Weight gms	Code
16- 3/8*	10	15	4.5	6	19	17	9	180	31 422 326
20- 1/2*	10	16.5	4.5	6	19	18	9	185	31 422 327
25- 1/2*	10	20	4.5	5	24	19	11	215	31 422 328
25- 3/4*	10	20	4.5	5	24	19	11	200	31 422 329

*Thread sizes designation.

ALL Durapipe Brass Components are manufactured using DZR Brass.

Flanges stub Plain serrated

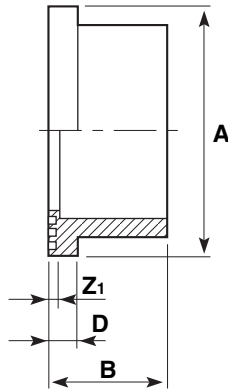

Size	PN	A	B	D	Z ₁	Weight gms	Code
16	10	29	17	6	3	5	11 135 305
20	10	34	20	6	3	8	11 135 306
25	10	41	22	7	3	13	11 135 307
32	10	50	26	7	3	19	11 135 308
40	10	61	30	8	3	36	11 135 309
50	10	73	35	8	3	60	11 135 310
63	10	90	42	9	4	100	11 135 311
75	10	106	49	10	4	150	11 135 312
90	10	125	59	11	6	240	11 135 313
110	10	149	68	12	6	370	11 135 314
125	10	165	76	13	5	520	11 135 315
140	10	180	83	14	7	680	11 135 316
160	10	205	93	16	5	930	11 135 317
200*	10	252	114	17	6	1520	11 135 318
225	10	273	126	24	6	1360	11 135 319
250	10	306	140	20	9	2140	11 135 320
315	10	375	180	32	14	5000	11 135 323

*The 200mm (NW175) stub flange supplied by Durapipe when used in conjunction with backing ring; code number 421 318 and 420 318 has a bolt circle diameter which matches 225mm (NW200) flanges (295mm PCD).

Flanges blanking

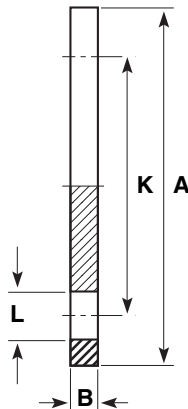

DIN 2501 16 bar/PN16

Size	PN	A	B	K	L	No. Holes	Weight gms	Code
32	10	116	13	85	14	4	139	11 323 308
40	10	141	13	100	18	4	204	11 323 309
50	10	153	13	110	18.5	4	237	11 323 310
63	10	166	19	124	18	4	447	11 323 311
75	10	186	19	145	18.5	4	568	11 323 312
90	10	201	19	159	18	8	645	11 323 313
110	10	221	26	180	18	8	715	11 323 314
125	10	251	26	210	18	8	1338	11 323 315
140	10	251	26	210	18	8	1338	11 323 316
160	10	286	27	240	23	8	1720	11 323 317

Note: Durapipe backing rings must be used in conjunction with blank flanges.

Backing rings Galvanised mild steel

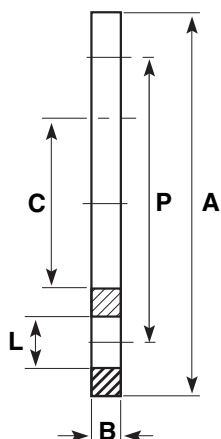

Drilled to DIN 2501 (BS4504) PN10/PN16

Size	A	B	C	P	L	No. Holes	Weight gms	Code
16	90	7	23	61	14	4	240	13 421 305
20	96	6	28	65	14	4	300	13 421 306
25	106	7	34	75	14	4	320	13 421 307
32	116	7	42	85	14	4	350	13 421 308
40	142	7	51	100	18	4	420	13 421 309
50	152	7	62	110	18	4	710	13 421 310
63	165	8	78	125	18	4	1010	13 421 311
75	186	9	92	145	18	4	1280	13 421 312
90	201	9	110	160	18	8	1380	13 421 313
110	220	9	133	180	18	8	1430	13 421 314
125	253	8	150	210	18	8	1960	13 421 315
140	251	11	167	210	18	8	2060	13 421 316
160	286	11	190	240	22	8	2700	13 421 317

Drilled to DIN 2501 (BS4504) PN10

Size	A	B	C	P	L	No. Holes	Weight gms	Code
200*	340	11	235	295	22	8	3830	13 421 318
225	340	11	249	295	22	8	3190	13 421 319
250	396	20	278	350	22	12	9450	13 421 320
315	448	20	355	402	22	12	8400	13 421 323

Drilled to DIN 2501 (BS4504) PN16

Size	A	B	C	P	L	No. Holes	Weight gms	Code
200*	340	11	235	295	22	12	3830	13 420 318
225	340	11	249	295	22	12	3190	13 420 319
250	405	20	278	355	26	12	9450	13 420 320
315	460	20	355	410	26	12	8400	13 420 323

Drilled to ANSI CLASS 150

Size	A	B	C	P	L	No. Holes	Weight gms	Code
20	90	8	28	61	16	4	300	13 448 306
25	100	8	34	70	16	4	380	13 448 307
32	110	9	42	79	16	4	480	13 448 308
40	118	8	51	90	16	4	530	13 448 309
50	129	8	63	99	16	4	590	13 448 310
63	154	10	78	121	19	4	1050	13 448 311
90	192	11	110	153	19	4	1470	13 448 313
110	230	11	133	190	19	8	2080	13 448 314

*The 200mm (NW175) stub flange supplied by Durapipe when used in conjunction with backing ring; code number 421 318 and 420 318 has a bolt circle diameter which matches 225mm (NW200) flanges (295mm PCD).

Flat gaskets for use with stub flanges

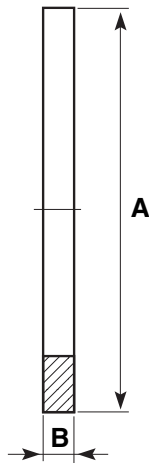

Size	A	B	Weight gms	EPDM Code
16	29	3.0	2	13 411 305
20	34	3.5	2	13 411 306
25	41	3.5	3	13 411 307
32	50	3.0	4	13 411 308
40	60	3.0	4	13 411 309
50	72	3.3	5	13 411 310
63	90	4.0	10	13 411 311
75	106	3.0	20	13 411 312
90	125	3.1	30	13 411 313
110	150	4.0	40	13 411 314
125	166	4.0	50	13 411 315
140	180	4.0	60	13 411 316
160	205	4.0	70	13 411 317
200	253	4.0	120	13 411 318
225	274	3.8	165	13 411 319
250	306	4.0	170	13 431 320
280	330	4.0	190	13 411 321
315	379	4.2	220	13 411 323

Valve support plates Galvanised steel

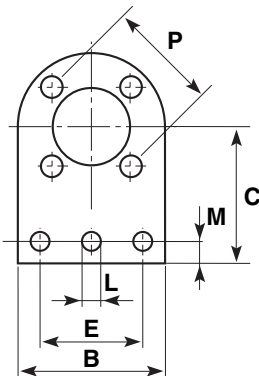

DIN 2501 16 bar/PN16

Size	B	C	E	L	M	N	P	No. Holes	Weight gms	Code
16	91	84	50	14	16	2	61	4	370	31 459 305
20	97	86	49	14	16	2	65	4	640	31 459 306
25	105	89	76	14	16	2	75	4	750	31 459 307
32	114	96	77	14	12	2	85	4	860	31 459 308
50	150	125	100	14	22	2	110	4	1480	31 459 310
63	160	134	100	14	24	2	125	4	2100	31 459 311
75	185	144	125	14	22	2	145	4	2500	31 459 312
90	203	150	127	14	23	2	160	8	2660	31 459 313
110	214	160	150	14	22	3	179	8	2960	31 459 314

N = No. of holes in base.

O-Ring sockets Galvanised steel



Size	ID	B	Weight gms	EPDM Code	FPM Code
16	15.54	2.62	23	23 209 305	23 211 305
20	20.22	3.53	39	23 209 306	23 211 306
25	28.17	3.53	68	23 209 307	23 211 307
32	32.93	3.53	94	23 209 308	23 211 308
40	40.65	5.34	163	23 209 309	23 211 309
50	47.00	5.34	190	23 209 310	23 211 310
63	59.69	5.34	355	23 209 311	23 211 311

Note: O-Rings EPDM.

Not end load resistant - for buried pipework only.

Valves

Premium Quality
Valve for Demanding
Environments

VKD Double union ball valves Manual – EPDM seals

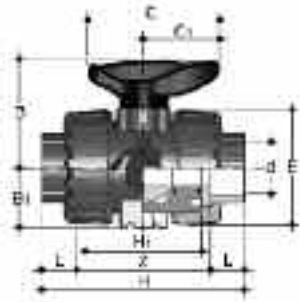

d	DN	PN	L	Z	H	E	B	C	Weight gms	Code
16	10	16	14	75	103	55	49	66	200	HO DKA 305
20	15	16	16	71	103	55	49	66	195	HO DKA 306
25	20	16	19	77	115	66	59	75	310	HO DKA 307
32	25	16	22	84	128	75	66	85	440	HO DKA 308
40	32	16	26	94	146	87	75	97	645	HO DKA 309
50	40	16	31	102	164	100	87	110	880	HO DKA 310
63	50	16	38	123	199	122	101	134	1490	HO DKA 311

Options:

FPM seals (plain ends) order HO DKB ***

For threaded versions refer to Imperial Valves section.

Manual valves can be supplied with locking kits - further information is available from our Valve Department.

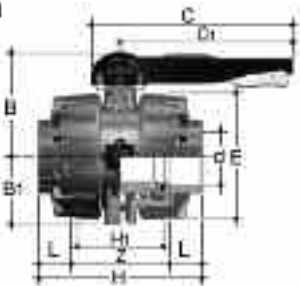

d	DN	PN	Z	L	H	H ₁	E	B	B ₁	C	C ₁	gms	Code
75	65	16	147	44	235	133	164	164	87	225	175	4380	HO DKA 312
90	80	16	168	51	270	149	203	177	105	327	272	7200	HO DKA 313
110	100	16	186	61	308	167	238	195	129	385	330	11141	HO DKA 314

Options:

FPM seals (plain ends) order HO DKB***

Premium Quality
Valve for Demanding
Environments

TKD 3-way ball valves Manual – EPDM seals

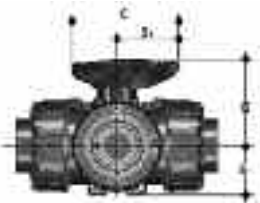

T port configuration

d	DN	PN	H	Z	C	C ₁	B	B ₁	gms	Code
20	15	16	118	86	67	40	54	29	310	HO TTA 306
25	20	16	145	107	85	49	65	34.5	550	HO TTA 307
32	25	16	160	116	85	49	65.9	39	790	HO TTA 308
40	32	16	188.5	136.5	108	64	82.5	46	1275	HO TTA 309
50	40	16	219	157	108	64	89	52	1660	HO TTA 310
63	50	16	266.5	190.5	134	76	108	62	2800	HO TTA 311

Options:

FPM seals (plain ends) order HO TTB***

FPM seals (threaded ends) order HO TTB***

Manual valves can be supplied with locking kits - further information is available from our Valve Department.

L port configuration

d	DN	PN	H	Z	C	C ₁	B	B ₁	gms	Code
20	15	16	118	86	67	40	54	29	310	HO LTA 306
25	20	16	145	107	85	49	65	34.5	550	HO LTA 307
32	25	16	160	116	85	49	65.9	39	790	HO LTA 308
40	32	16	188.5	136.5	108	64	82.5	46	1275	HO LTA 309
50	40	16	219	157	108	64	89	52	1660	HO LTA 310
63	50	16	266.5	190.5	134	76	108	62	2800	HO LTA 311

Options:

FPM seals (plain ends) order HO LTB***

VKD & TKD ball valves can be supplied electrically or pneumatically actuated.

EV Double union ball valves Manual – EPDM seals

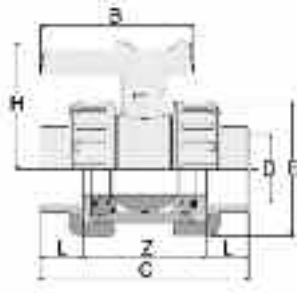

d	DN	PN	L	Z	C	E	H	B	Weight gms	Code
20	15	10	17	47	81	50	50	57	95	HO EVA 306
25	20	10	19	51	95	59	55	66	156	HO EVA 307
32	25	10	22	61	105	68	66.5	75	228	HO EVA 308
40	32	10	31	84	146	96	93	103	540	HO EVA 309
50	40	10	31	84	146	96	93	103	540	HO EVA 310
63	50	10	38	96	172	116	107	121	844	HO EVA 311

For threaded versions refer to Imperial Valves section.

UC Ball check valves EPDM seals

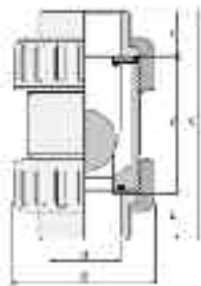

Size	L	Z	C	E	Weight gms	Code
20	17	48	82	50	96	HO UCA 306
25	19	55	93	59	99	HO UCA 307
32	22	62	106	68	145	HO UCA 308
40	26	75	127	80	234	HO UCA 309
50	31	84	146	96	357	HO UCA 310
63	38	99	175	116	937	HO UCA 311

Options:

FPM seals (plain ends) order HO UCB***

For threaded versions refer to Imperial Valves section.

Note: this valve must be installed at a minimum distance of 10 x nominal diameter (eg. 20" for size 63mm) from pump flange.

UA Air release valves EPDM seals

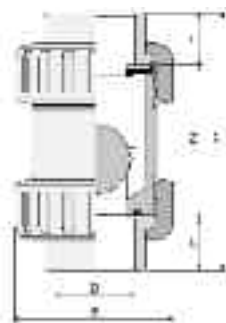

Size	L	Z	C	E	Weight gms	Code
20	17	48	82	50	96	HO UAA 306
25	19	55	93	59	99	HO UAA 307
32	22	62	106	68	145	HO UAA 308
40	26	75	127	80	234	HO UAA 309
50	31	84	146	96	357	HO UAA 310
63	38	99	175	116	937	HO UAA 311

Options:

FPM seals (plain ends) order HO UAB***

For threaded versions refer to Imperial Valves section.

RV Y-Type strainers Plain ends – EPDM seals

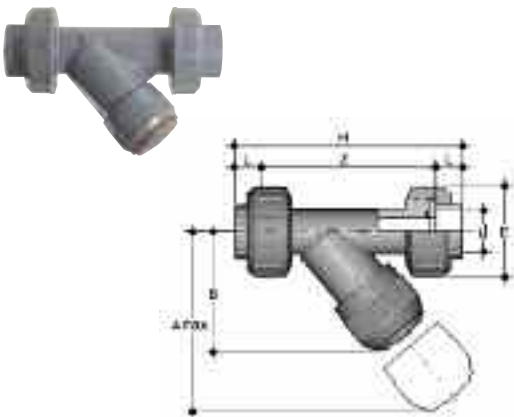

D	DN	PN	A	B	E	L	Z	H	Fig.	gms	Code	
Grey			max									
20	15	16	125	72	55	16	103	135	A	211	HO UVA 306	
25	20	16	145	84	66	19	120	158	A	358	HO UVA 307	
32	25	16	165	95	75	22	132	176	A	256	HO UVA 308	
40	32	16	190	111	87	26	155	207	A	733	HO UVA 309	
50	40	16	210	120	100	31	181	243	A	1095	HO UVA 310	
63	50	10	240	139	120	38	222	298	A	1843	HO UVA 311	

Options:

FPM seals (plain ends) order HO UVB ***
For threaded versions refer to Imperial Valves section.

VM Diaphragm valves Manual – plain union ends – EPDM seals



d	DN	PN	B	B ₁	H	h	H ₁	J	L	gms	Code
20	15	10	95	26	124	12	90	M6	16	700	HO UMA 306
25	20	10	95	26	144	12	90	M6	19	700	HO UMA 307
32	25	10	95	26	154	12	90	M6	23	700	HO UMA 308
40	32	10	126	40	174	18	115	M8	27	1500	HO UMA 309
50	40	10	126	40	194	18	115	M8	32	1500	HO UMA 310
63	50	10	148	40	224	18	140	M8	39	2400	HO UMA 311
* 75	65	10	225	55	284	23	215	M12	44	7000	HO VMA 412
* 90	80	10	225	55	300	23	215	M12	51	7000	HO VMA 413
* 110	100	10	295	69	350	23	250	M12	61	10500	HO VMA 414

Options:

FPM diaphragm order HO VMB***
PTFE diaphragm order HO VMC***

Manual Valves can be supplied with locking kits - further information is available from our Valve Department.

*Note: 75mm, 90mm and 110mm are spigot ended.

PR Pressure relief valves EPDM seals

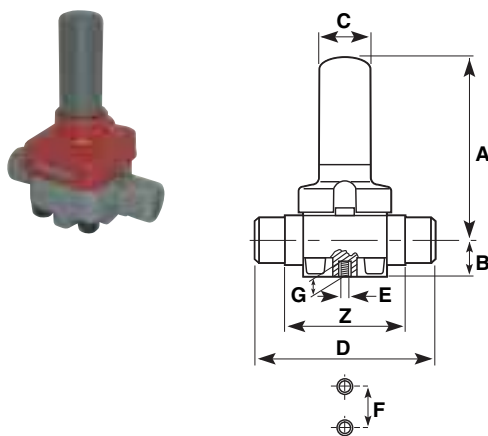

Size	PN	Z	A	B	C	D	E	F	G	gms	Code
20	10	92	143	20.5	35	124	M6	25	12	700	HO PRA 406
25	10	106	143	20.5	35	144	M6	25	12	700	HO PRA 407
32	10	108	143	25.0	35	154	M6	25	12	700	HO PRA 408
40	10	120	204	36.0	50	174	M8	44.5	16	1500	HO PRA 409
50	10	130	204	39.5	50	194	M8	44.5	16	1500	HO PRA 410
63	10	146	219	49.0	50	224	M8	44.5	16	2400	HO PRA 411

Options:

FPM seals order HO PRB***

FK Butterfly valves Glass reinforced polypropylene with ABS disc



lever operated

d	DN	PN	B ₂	B ₃	C	C ₁	gms	U	Z	Code
50	40	16	60	137	175	100	900	4	33	HO FKA 106
63	50	16	70	143	175	100	1080	4	43	HO FKA 107
75	65	10	80	164	272	110	1470	4	46	HO FKA 108
90	80	10	93	178	272	110	1870	8	49	HO FKA 109
110	100	10	107	192	272	110	2220	8	56	HO FKA 110
140	125	10	120	212	330	110	3100	8	64	HO FKA 111
160	150	10	134	225	330	110	3850	8	70	HO FKA 112
225	200	10	161	272	420	122	6750	8	71	HO FKA 113

Options:

FPM seals order HO FKB***

U = No. of holes

with gear box

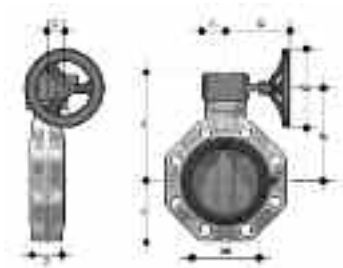

Size	DN	PN	B ₂	B ₅	B ₆	G	G ₁	G ₂	G ₃	gms	U	Z	Code
75	65	10	80	174	146	48	135	39	125	2400	4	46	HV FKA 108
90	80	10	93	188	160	48	135	39	125	2800	8	49	HV FKA 109
110	100	10	107	202	174	48	135	39	125	3150	8	56	HV FKA 110
140	125	10	120	222	194	48	144	39	200	4450	8	64	HV FKA 111
160	150	10	134	235	207	48	144	39	200	5200	8	70	HV FKA 112
225	200	10	161	287	256	65	204	60	200	9300	8	71	HV FKA 113
250	250	10	210	317	281	88	236	76	250	18600	12	114	HV FKA 114
315	300	8	245	374	338	88	236	76	250	25600	12	114	HV FKA 115

Options:

FPM seals order HV FKB***

U = No. of holes

Note: Lugged versions available to special order. Please refer to our Valve Department for further details.

Valves can be supplied as electrically or pneumatically actuated.
Contact our Valve department on 01543 272424 for further information.

Accessories

Cobra pipe clips

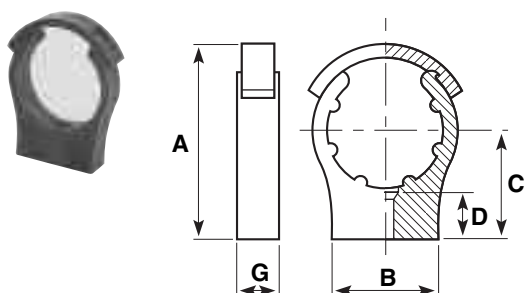

Size	A	B	C	D	G	Bolt/Screw	gms	Code
*12	-	24	25	15	16	M4/3BA/No 8	5	13 434 304
*16	-	35	25	17	16	M4/3BA/No 8	7	13 434 305
*20	-	35	30	14	16	M5/1BA/No 10	8	13 434 306
*25	-	35	35	16	17	M5/1BA/No 10	11	13 434 307
32	65	45	40	17	17	M5/1BA/No 10	14	13 434 308
40	75	45	45	20	20	M5/1BA/No 10	21	13 434 309
50	85	50	50	22	21	M6/0BA/No 10	30	13 434 310
63	102	60	60	19	21	M6/0BA/No 10	42	13 434 311
75	122	70	70	27	31	M8	94	13 434 312
90	148	80	90	39	31	M8	121	13 434 313
110	171	90	96	36	35	M8	184	13 434 314
125	204	144	132	40	40	M8	237	13 434 315
140	211	156	132	40	40	M8	252	13 434 316
160	243	170	150	40	40	M8	330	13 434 317

*Without retaining clips. Bolts/screws not supplied.

Rubber lined pipe clips

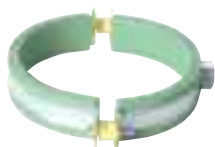

Size mm	Thread	Code
16	M10	FT PC 1600
20	M10	FT PC 2000
25	M10	FT PC 2500
32	M10	FT PC 3200
40	M10	FT PC 4000
50	M10	FT PC 5000
63	M10	FT PC 6300
75	M10	FT PC 7500
90	M10	FT PC 9000
110	M10	FT PC 1100
160	M10	FT PC 1601

One-step solvent cement



Litres	gms	Code
0.5	550	03 461 395
1.0	1100	03 461 396

Only Durapipe ABS solvent cement and Durapipe Eco-cleaner should be used for jointing of Durapipe ABS pipework systems.

Eco-cleaner



Litres	gms	Code
0.5	500	03 457 395

Only Durapipe ABS solvent cement and Durapipe Eco-cleaner should be used for jointing of Durapipe ABS pipework systems.

Pipe trays



Pipe dia mm	Standard length in metres	Standard pack quantity in metres	Product code
16	2	50	FT 635 216
20	2	50	FT 635 220
25	2	50	FT 635 225
32	2	50	FT 635 232

Chamfering and de-burring tools



Description	Product code
E 16-25mm pipe inner and outer milling cutter tool	FT 55 72 90
E 16-63mm pipe inner and outer milling cutter tool	FT 55 65 12
32-160mm chamfering tool	FT 55 05 10

Pipe cutters



Description	Product code
16-63mm pipe cutter	FT 80 00 01
50-125mm pipe cutter	FT 80 00 03
16-63mm spare cutter wheel	FT 80 00 02
50-125mm spare cutter wheel	FT 80 00 04